

CD74HCT4066-Q1 HIGH-SPEED CMOS LOGIC QUAD BILATERAL SWITCH

SCLS581B – APRIL 2004 – REVISED APRIL 2008

- Qualified for Automotive Applications
- Low ON Resistance
– 25 Ω Typical ($V_{CC} = 4.5\text{ V}$)
- Fast Switching and Propagation Speeds
- Low OFF Leakage Current
- Wide Operating Temperature Range: -40°C to 125°C
- Direct LSTTL Input Logic Compatibility:
 $V_{IL} = 0.8\text{ V Max}$, $V_{IH} = 2\text{ V Min}$
- CMOS Input Compatibility: $I_I \leq 1\ \mu\text{A}$ at V_{OL} , V_{OH}

description/ordering information

The CD74HCT4066 contains four independent digitally controlled analog switches that use silicon-gate CMOS technology to achieve operation speeds similar to LSTTL, with the low power consumption of standard CMOS integrated circuits.

These switches feature the characteristic linear ON resistance of the metal-gate CD4066B. Each switch is turned on by a high-level voltage on its control input.

M OR PW PACKAGE
(TOP VIEW)

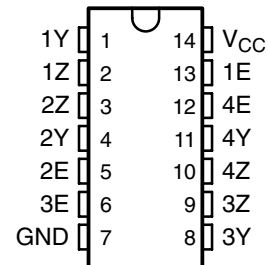

ORDERING INFORMATION†

T _A	PACKAGE‡		ORDERABLE PART NUMBER§	TOP-SIDE MARKING
	SOIC – M	Reel of 2500		
–40°C to 125°C	SOIC – M	Reel of 2500	CD74HCT4066QM96Q1	HCT4066Q
	TSSOP – PW	Reel of 2000	CD74HCT4066QPWRQ1	HK4066Q

† For the most current package and ordering information, see the Package Option Addendum at the end of this document, or see the TI web site at <http://www.ti.com>.

‡ Package drawings, thermal data, and symbolization are available at <http://www.ti.com/packaging>.

§ The suffix 96 denotes tape and reel.

FUNCTION TABLE

INPUT nE	SWITCH
L	Off
H	On

H = High level

L = Low level



Please be aware that an important notice concerning availability, standard warranty, and use in critical applications of Texas Instruments semiconductor products and disclaimers thereto appears at the end of this data sheet.

PRODUCTION DATA information is current as of publication date. Products conform to specifications per the terms of Texas Instruments standard warranty. Production processing does not necessarily include testing of all parameters.

 **TEXAS
INSTRUMENTS**

POST OFFICE BOX 655303 • DALLAS, TEXAS 75265

Copyright © 2008, Texas Instruments Incorporated

recommended operating conditions (see Note 4)

		MIN	MAX	UNIT
V _{CC}	Supply voltage	4.5	5.5	V
V _{IH}	High-level input voltage	2		V
V _{IL}	Low-level input voltage		0.8	V
V _I	Input voltage	0	V _{CC}	V
V _O	Output voltage	0	V _{CC}	V
t _t	Input transition (rise and fall) time	V _{CC} = 4.5 V		0 500 ns
T _A	Operating free-air temperature	-40	125	°C

NOTES: 4. All unused inputs of the device must be held at V_{CC} or GND to ensure proper device operation. Refer to the TI application report, *Implications of Slow or Floating CMOS Inputs*, literature number SCBA004.

electrical characteristics over recommended operating free-air temperature range (unless otherwise noted)

PARAMETER	TEST CONDITIONS	V _I	V _{CC}	T _A = 25°C			T _A = -40°C TO 125°C		UNIT
				MIN	TYP	MAX	MIN	MAX	
I _{IL}	Any control	V _{CC} or GND	5.5 V			±0.1		±1	μA
I _{Iz}	V _{IS} = V _{CC} or GND	V _{IL}	5.5 V			±0.1		±1	μA
r _{on}	I _O = 1 mA, See Figure 7	V _{IS} = V _{CC} or GND	V _{CC}	4.5 V	25	80		128	Ω
		V _{IS} = V _{CC} to GND	V _{CC}	4.5 V		35	95		
Δr _{on}	Between any two switches	V _{CC}	4.5 V		1				Ω
I _{CC}		V _{CC} or GND	5.5 V			2		40	μA
ΔI _{CC}	Per input pin: 1 unit load, See Note 5	V _{CC} - 2.1 V	4.5 V to 5.5 V		100	360		490	μA
C _I	Control inputs					10		10	pF

NOTE 5: For dual-supply systems, theoretical worst case (V_I = 2.4 V, V_{CC} = 5.5 V) specification is 1.8 mA.

HCT input loading

INPUT	UNIT LOADS†
All	1

† Unit load is ΔI_{CC} limit specified in the electrical characteristics table, e.g., 360 μA max at 25°C.

CD74HCT4066-Q1
HIGH-SPEED CMOS LOGIC
QUAD BILATERAL SWITCH
 SCLS581B – APRIL 2004 – REVISED APRIL 2008

switching characteristics over recommended operating free-air temperature range (unless otherwise noted) (see Figure 6)

PARAMETER	FROM (INPUT)	TO (OUTPUT)	LOAD CAPACITANCE	V _{CC}	T _A = 25°C			T _A = -40°C TO 125°C		UNIT
					MIN	TYP	MAX	MIN	MAX	
t _{pd}	Y or Z	Z or Y	C _L = 15 pF	5 V	4					ns
			C _L = 50 pF	4.5 V	12			18		
t _{en}	E	Y or Z	C _L = 15 pF	5 V	9					ns
			C _L = 50 pF	4.5 V	24			36		
t _{dis}	E	Y or Z	C _L = 15 pF	5 V	14					ns
			C _L = 50 pF	4.5 V	35			53		

operating characteristics, V_{CC} = 5 V, T_A = 25°C, input t_r, t_f = 6 ns

PARAMETER	TYP	UNIT
C _{pd} Power dissipation capacitance (see Note 6)	38	pF

NOTE 6: C_{pd} is used to determine the dynamic power consumption (P_D), per package.

$$P_D = (C_{pd} \times V_{CC}^2 \times f_i) + \Sigma (C_L + C_S) \times V_{CC}^2 \times f_O$$

f_O = output frequency

f_I = input frequency

C_L = output load capacitance

C_S = switch capacitance

V_{CC} = supply voltage

analog channel characteristics, T_A = 25°C

PARAMETER	TEST CONDITIONS	V _{CC}	TYP	UNIT
f _{max} Switch frequency response bandwidth at -3 dB	See Figure 2 and Figure 8 and Notes 7 and 8	4.5 V	200	MHz
Crosstalk between any two switches	See Figure 1 and Figure 9 and Notes 8 and 9	4.5 V	-72	dB
Total harmonic distortion	See Figure 3, 1 kHz, V _{IS} = 4 V _{P-P}	4.5 V	0.023	%
Control to switch feedthrough noise	See Figure 4	4.5 V	130	mV
Switch OFF signal feedthrough	See Figure 5 and Figure 9 and Notes 8 and 9	4.5 V	-72	dB
C _S Switch input capacitance			5	pF

NOTES: 7. Adjust input voltage to obtain 0 dBm at output, f = 1 MHz.

8. V_{IS} is centered at V_{CC}/2.

9. Adjust input for 0 dBm at V_{IS}.



PARAMETER MEASUREMENT INFORMATION

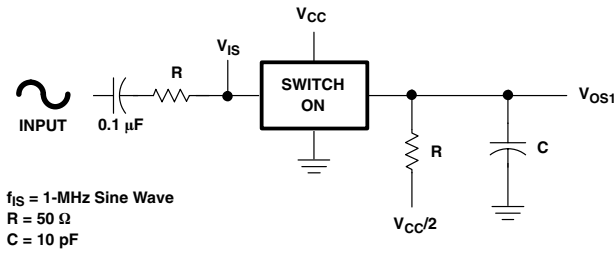

Figure 1. Crosstalk Between Two Switches Test Circuit

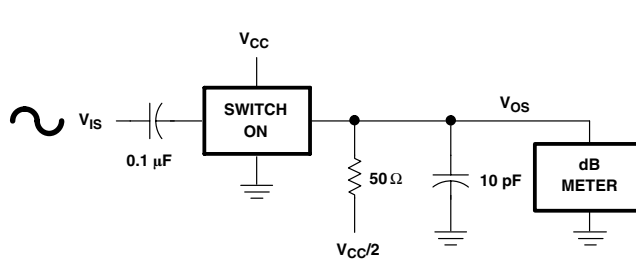
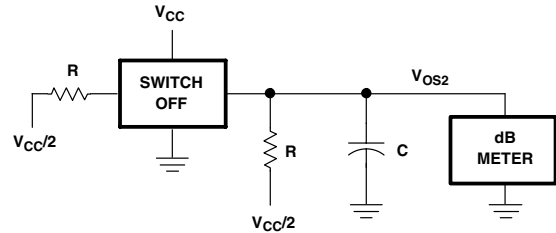

Figure 2. Frequency-Response Test Circuit

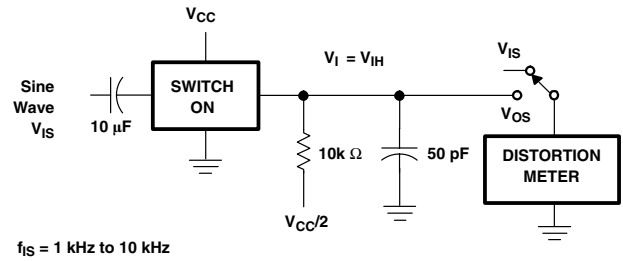

Figure 3. Total Harmonic Distortion Test Circuit

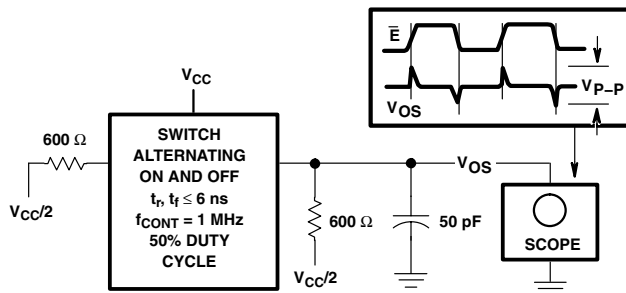

Figure 4. Control-to-Switch Feedthrough Noise Test Circuit

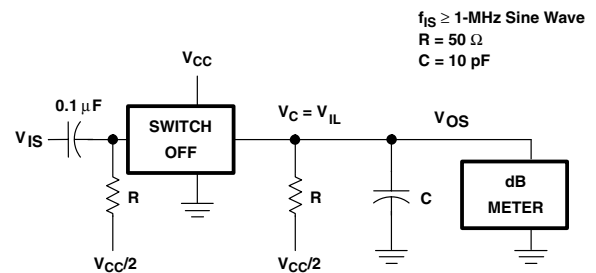
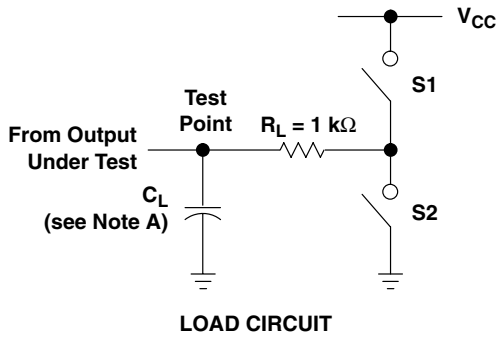
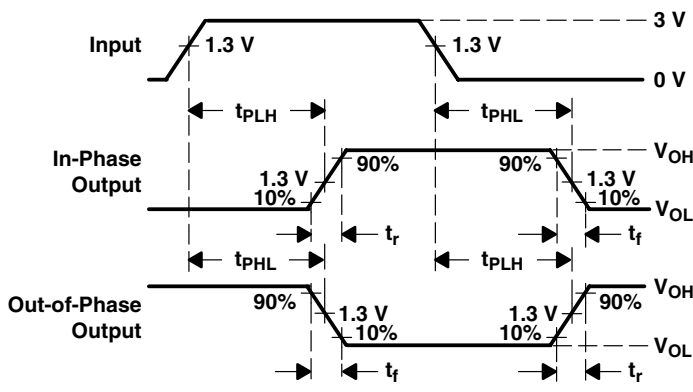

Figure 5. Switch OFF Signal Feedthrough Test Circuit

PARAMETER MEASUREMENT INFORMATION



PARAMETER		S1	S2
t_{en}	t_{pZH}	Open	Closed
	t_{pZL}	Closed	Open
t_{dis}	t_{pHZ}	Open	Closed
	t_{pLZ}	Closed	Open
t_{pd}		Open	Open



VOLTAGE WAVEFORMS
PROPAGATION DELAY AND OUTPUT TRANSITION TIMES

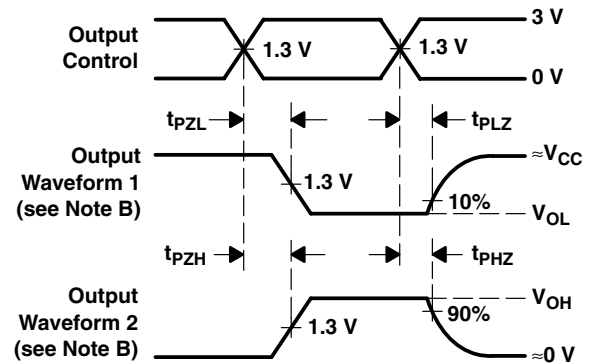

VOLTAGE WAVEFORMS
OUTPUT ENABLE AND DISABLE TIMES

- NOTES: A. C_L includes probe and test-fixture capacitance.
 B. Waveform 1 is for an output with internal conditions such that the output is low, except when disabled by the output control. Waveform 2 is for an output with internal conditions such that the output is high, except when disabled by the output control.
 C. Phase relationships between waveforms were chosen arbitrarily. All input pulses are supplied by generators having the following characteristics: $PRR \leq 1$ MHz, $Z_O = 50 \Omega$, $t_r = 6$ ns, $t_f = 6$ ns.
 D. For clock inputs, f_{max} is measured with the input duty cycle at 50%.
 E. The outputs are measured one at a time, with one input transition per measurement.
 F. t_{PLZ} and t_{PHZ} are the same as t_{dis} .
 G. t_{PZL} and t_{PZH} are the same as t_{en} .
 H. t_{PLH} and t_{PHL} are the same as t_{pd} .

Figure 6. Load Circuit and Voltage Waveforms

TYPICAL CHARACTERISTICS

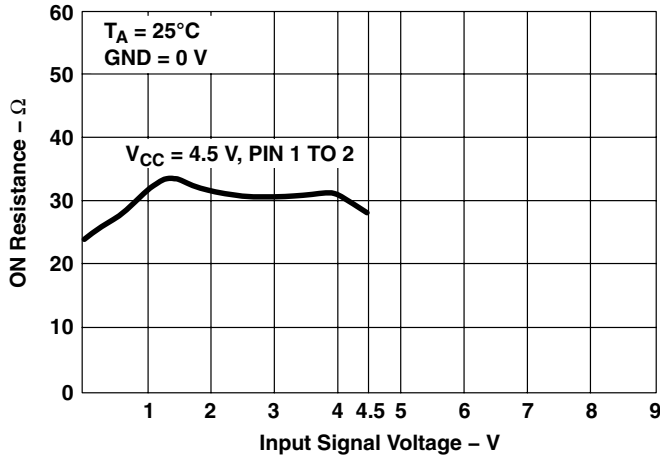

Figure 7. Typical ON Resistance vs Input Signal Voltage

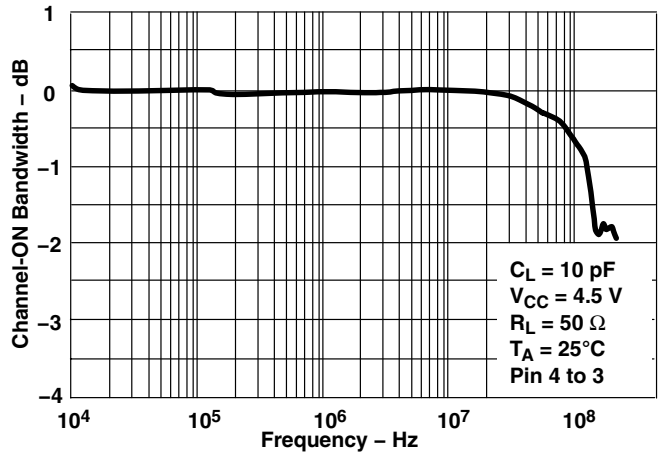

Figure 8. Switch Frequency Response, $V_{CC} = 4.5 \text{ V}$

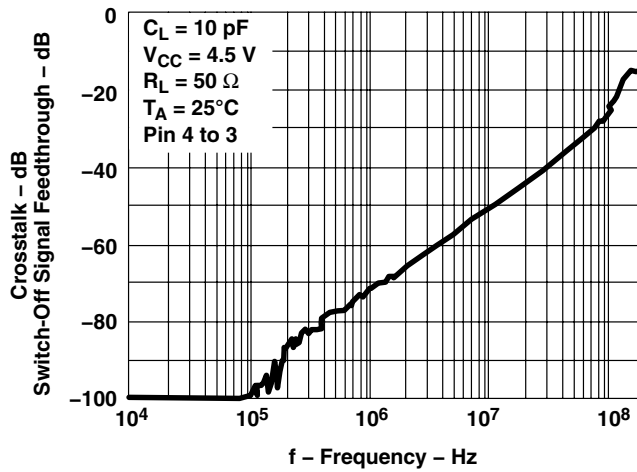

Figure 9. Switch-OFF Signal Feedthrough and Crosstalk vs Frequency, $V_{CC} = 4.5 \text{ V}$

PACKAGING INFORMATION

Orderable Device	Status ⁽¹⁾	Package Type	Package Drawing	Pins	Package Qty	Eco Plan ⁽²⁾	Lead/Ball Finish	MSL Peak Temp ⁽³⁾
CD74HCT4066QM96Q1	ACTIVE	SOIC	D	14	2500	Green (RoHS & no Sb/Br)	CU NIPDAU	Level-1-260C-UNLIM
CD74HCT4066QPWRQ1	ACTIVE	TSSOP	PW	14	2000	Pb-Free (RoHS)	CU NIPDAU	Level-1-250C-UNLIM
D24066QM96G4Q1	ACTIVE	SOIC	D	14	2500	Green (RoHS & no Sb/Br)	CU NIPDAU	Level-1-260C-UNLIM
HCT4066QPWRG4Q1	ACTIVE	TSSOP	PW	14	2000	Green (RoHS & no Sb/Br)	CU NIPDAU	Level-1-260C-UNLIM

⁽¹⁾ The marketing status values are defined as follows:

ACTIVE: Product device recommended for new designs.

LIFEBUY: TI has announced that the device will be discontinued, and a lifetime-buy period is in effect.

NRND: Not recommended for new designs. Device is in production to support existing customers, but TI does not recommend using this part in a new design.

PREVIEW: Device has been announced but is not in production. Samples may or may not be available.

OBSOLETE: TI has discontinued the production of the device.

⁽²⁾ Eco Plan - The planned eco-friendly classification: Pb-Free (RoHS), Pb-Free (RoHS Exempt), or Green (RoHS & no Sb/Br) - please check <http://www.ti.com/productcontent> for the latest availability information and additional product content details.

TBD: The Pb-Free/Green conversion plan has not been defined.

Pb-Free (RoHS): TI's terms "Lead-Free" or "Pb-Free" mean semiconductor products that are compatible with the current RoHS requirements for all 6 substances, including the requirement that lead not exceed 0.1% by weight in homogeneous materials. Where designed to be soldered at high temperatures, TI Pb-Free products are suitable for use in specified lead-free processes.

Pb-Free (RoHS Exempt): This component has a RoHS exemption for either 1) lead-based flip-chip solder bumps used between the die and package, or 2) lead-based die adhesive used between the die and leadframe. The component is otherwise considered Pb-Free (RoHS compatible) as defined above.

Green (RoHS & no Sb/Br): TI defines "Green" to mean Pb-Free (RoHS compatible), and free of Bromine (Br) and Antimony (Sb) based flame retardants (Br or Sb do not exceed 0.1% by weight in homogeneous material)

⁽³⁾ MSL, Peak Temp. -- The Moisture Sensitivity Level rating according to the JEDEC industry standard classifications, and peak solder temperature.

Important Information and Disclaimer:The information provided on this page represents TI's knowledge and belief as of the date that it is provided. TI bases its knowledge and belief on information provided by third parties, and makes no representation or warranty as to the accuracy of such information. Efforts are underway to better integrate information from third parties. TI has taken and continues to take reasonable steps to provide representative and accurate information but may not have conducted destructive testing or chemical analysis on incoming materials and chemicals. TI and TI suppliers consider certain information to be proprietary, and thus CAS numbers and other limited information may not be available for release.

In no event shall TI's liability arising out of such information exceed the total purchase price of the TI part(s) at issue in this document sold by TI to Customer on an annual basis.

OTHER QUALIFIED VERSIONS OF CD74HCT4066-Q1 :

- Catalog: [CD74HCT4066](#)



NOTE: Qualified Version Definitions:

- Catalog - TI's standard catalog product

D (R-PDSO-G14)

PLASTIC SMALL OUTLINE



- NOTES:
- A. All linear dimensions are in inches (millimeters).
 - B. This drawing is subject to change without notice.
 -  Body length does not include mold flash, protrusions, or gate burrs. Mold flash, protrusions, or gate burrs shall not exceed 0.006 (0,15) each side.
 -  Body width does not include interlead flash. Interlead flash shall not exceed 0.017 (0,43) each side.
 - E. Reference JEDEC MS-012 variation AB.

PW (R-PDSO-G14)

PLASTIC SMALL OUTLINE

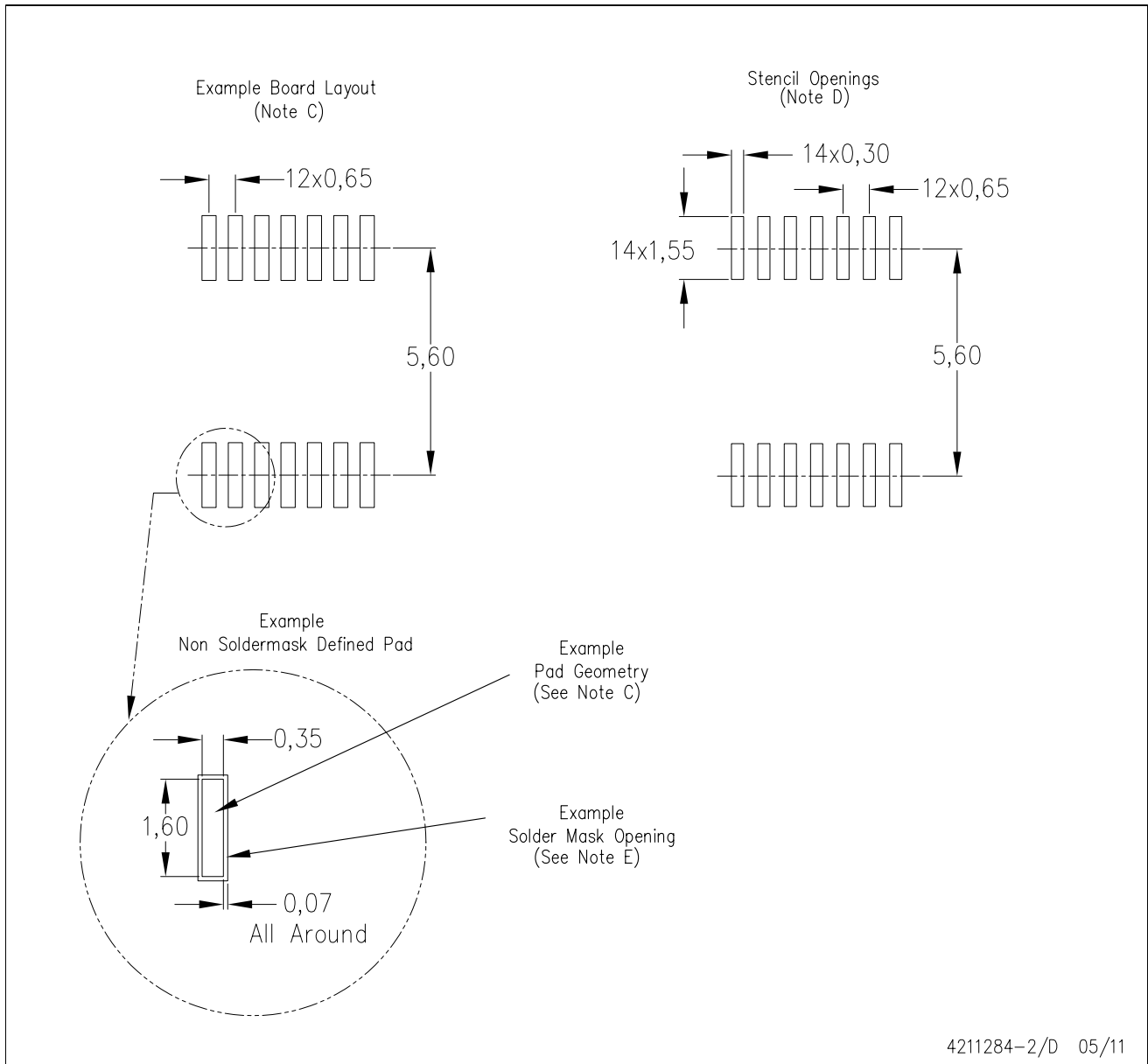

- NOTES:
- All linear dimensions are in millimeters.
 - This drawing is subject to change without notice.
 - Publication IPC-7351 is recommended for alternate designs.
 - Laser cutting apertures with trapezoidal walls and also rounding corners will offer better paste release. Customers should contact their board assembly site for stencil design recommendations. Refer to IPC-7525 for other stencil recommendations.
 - Customers should contact their board fabrication site for solder mask tolerances between and around signal pads.

IMPORTANT NOTICE

Texas Instruments Incorporated and its subsidiaries (TI) reserve the right to make corrections, modifications, enhancements, improvements, and other changes to its products and services at any time and to discontinue any product or service without notice. Customers should obtain the latest relevant information before placing orders and should verify that such information is current and complete. All products are sold subject to TI's terms and conditions of sale supplied at the time of order acknowledgment.

TI warrants performance of its hardware products to the specifications applicable at the time of sale in accordance with TI's standard warranty. Testing and other quality control techniques are used to the extent TI deems necessary to support this warranty. Except where mandated by government requirements, testing of all parameters of each product is not necessarily performed.

TI assumes no liability for applications assistance or customer product design. Customers are responsible for their products and applications using TI components. To minimize the risks associated with customer products and applications, customers should provide adequate design and operating safeguards.

TI does not warrant or represent that any license, either express or implied, is granted under any TI patent right, copyright, mask work right, or other TI intellectual property right relating to any combination, machine, or process in which TI products or services are used. Information published by TI regarding third-party products or services does not constitute a license from TI to use such products or services or a warranty or endorsement thereof. Use of such information may require a license from a third party under the patents or other intellectual property of the third party, or a license from TI under the patents or other intellectual property of TI.

Reproduction of TI information in TI data books or data sheets is permissible only if reproduction is without alteration and is accompanied by all associated warranties, conditions, limitations, and notices. Reproduction of this information with alteration is an unfair and deceptive business practice. TI is not responsible or liable for such altered documentation. Information of third parties may be subject to additional restrictions.

Resale of TI products or services with statements different from or beyond the parameters stated by TI for that product or service voids all express and any implied warranties for the associated TI product or service and is an unfair and deceptive business practice. TI is not responsible or liable for any such statements.

TI products are not authorized for use in safety-critical applications (such as life support) where a failure of the TI product would reasonably be expected to cause severe personal injury or death, unless officers of the parties have executed an agreement specifically governing such use. Buyers represent that they have all necessary expertise in the safety and regulatory ramifications of their applications, and acknowledge and agree that they are solely responsible for all legal, regulatory and safety-related requirements concerning their products and any use of TI products in such safety-critical applications, notwithstanding any applications-related information or support that may be provided by TI. Further, Buyers must fully indemnify TI and its representatives against any damages arising out of the use of TI products in such safety-critical applications.

TI products are neither designed nor intended for use in military/aerospace applications or environments unless the TI products are specifically designated by TI as military-grade or "enhanced plastic." Only products designated by TI as military-grade meet military specifications. Buyers acknowledge and agree that any such use of TI products which TI has not designated as military-grade is solely at the Buyer's risk, and that they are solely responsible for compliance with all legal and regulatory requirements in connection with such use.

TI products are neither designed nor intended for use in automotive applications or environments unless the specific TI products are designated by TI as compliant with ISO/TS 16949 requirements. Buyers acknowledge and agree that, if they use any non-designated products in automotive applications, TI will not be responsible for any failure to meet such requirements.

Following are URLs where you can obtain information on other Texas Instruments products and application solutions:

Products

Audio	www.ti.com/audio
Amplifiers	amplifier.ti.com
Data Converters	dataconverter.ti.com
DLP® Products	www.dlp.com
DSP	dsp.ti.com
Clocks and Timers	www.ti.com/clocks
Interface	interface.ti.com
Logic	logic.ti.com
Power Mgmt	power.ti.com
Microcontrollers	microcontroller.ti.com
RFID	www.ti-rfid.com
RF/IF and ZigBee® Solutions	www.ti.com/lprf

Applications

Communications and Telecom	www.ti.com/communications
Computers and Peripherals	www.ti.com/computers
Consumer Electronics	www.ti.com/consumer-apps
Energy and Lighting	www.ti.com/energy
Industrial	www.ti.com/industrial
Medical	www.ti.com/medical
Security	www.ti.com/security
Space, Avionics and Defense	www.ti.com/space-avionics-defense
Transportation and Automotive	www.ti.com/automotive
Video and Imaging	www.ti.com/video
Wireless	www.ti.com/wireless-apps

TI E2E Community Home Page

e2e.ti.com

Mailing Address: Texas Instruments, Post Office Box 655303, Dallas, Texas 75265
Copyright © 2011, Texas Instruments Incorporated